



Understanding Capacitive Position Sensors

ADE Technologies Inc.

80 Wilson Way Westwood, Massachusetts 02090 USA www.adetech.com

©2009 ADE Technologies Inc.

Table of Contents

1.	Introduction to Capacitive Sensors	3
1.1	Characteristics of Capacitive Sensors.....	3
1.1.1	Non Contact	3
1.1.2	High Resolution.....	3
1.1.3	High Bandwidth	3
1.2	Principle of Operation	4
1.3	Concept Refinement.....	4
1.4	Types of Capacitive Sensors	6
1.5	Performance:.....	7
1.5.1	Sensor Size.....	7
1.5.2	Sensor Size depends on target shape.....	7
1.5.3	Spatial Resolution.....	8
1.5.4	Range & Standoff.....	8
1.5.5	Resolution	9
1.5.6	Bandwidth.....	9
1.5.7	Linearity	9
1.5.8	Stability	10
1.6	Target Characteristics	10
1.7	Environmental Considerations.....	10
1.8	Fixturing	11
1.8.1	Probe Clamping	11
1.8.2	Target Angle.....	11
1.8.3	Cable Fixtures	12

1. Introduction to Capacitive Displacement Sensors

Capacitance sensing is a high precision, high bandwidth, non contact displacement measurement method which has been in common use for over 50 years. This white paper describes various characteristics of capacitive sensing, principles of operation, performance characteristics and the fixturing of capacitive sensors.

Capacitive sensors, when used for high resolution displacement and position measurement, are also commonly known as cap gages (or gauges), since some of the early commercial applications for capacitive sensors involved dimensional gaging of precision components.

1.1 Characteristics of Capacitive Sensors

Capacitive sensors are used to make non contact displacement measurements with high precision, very rapidly over modest ranges.

1.1.1 Non Contact

Capacitive sensing is a non contact measurement method. Because the system never makes contact with the part there are no witness marks, parts distortion or probe wear. In addition, because the system is non contact, high volume measurements are facilitated because there is no sensor cycle time.

1.1.2 High Resolution

Only a laser interferometer offers similar resolution to a capacitive sensor. Capacitive sensors are used in many of the most demanding measurement applications such as diamond turning fast tool servo, high precision spindle analysis, wafer surface detection in semiconductor equipment, and many others. Typical resolutions range from 0.1 nm (0.004 μ in) to 50 nm (2 μ in) Operating ranges are normally less than 3 mm (1/8 inch)

1.1.3 High Bandwidth

Capacitive Sensors are capable of measuring very quickly. They are ideally suited to high volume sorting applications and high bandwidth measurements applications.

1.2 Principle of Operation

A capacitor is formed when 2 parallel conductive plates are brought near each other and a charge is placed on one of the plates. Current then flows across the gap between the plates. The amount of current that flows across the gap is determined by the voltage, the area of the plates, the material that separates the plates and the distance between the plates.

In formal terms:

$$Q = C * V$$

Where:

Q = Current (amps)
C = Capacitance (farads)
V = Voltage

Capacitance (C) in turn is defined as:

$$C = K * E_0 * A / D$$

Where

C = Capacitance (farads)
K = The Dielectric Constant of the material between the plates. (Air=1.0)
 E_0 = Permittivity of free space (a constant)
A = Area of the plates (Meters²)
D = Distance between the plates (Meters)

At its simplest, a capacitive sensor is a parallel plate capacitor where the voltage (V), and the area (A) of the plates is held constant and as such all the changes in current (Q) are due to changes in the distance (D) between the plates.

A capacitive sensor is a device that measures the displacement of 2 parallel plates one of which is a sensor and the other of which is the object being measured by the sensor.

1.3 Concept Refinement

In a capacitive sensor the voltage is typically provided by an AC signal. This signal has a frequency of between a few kilohertz and a few megahertz depending on the basic design. Voltages range from a few volts to a few hundred again depending on the design. Some capacitive sensors hold the current constant and allow the voltage to vary, these are called constant current capacitive sensors. Others hold the voltage constant and allow the current to vary (ADE Technologies MicroSense series), these are constant voltage designs. There is no inherent advantage of one design over the other. The balance of this paper will describe the workings of a constant voltage (variable current) system but a constant current system works in the same way.

Almost all capacitive sensors are divided between an electronics package (known as a gauging module or demodulator) and a sensor, commonly referred to a probe. A simple capacitive probe can be drawn as follows”

Fig 1 A Simple Capacitive Sensor (side view)

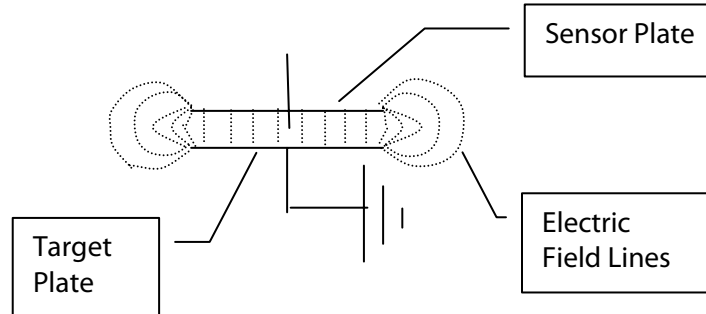

One thing is immediately obvious from figure 1. The electric field lines between the 2 plates extend beyond the edges of the sensor plate. This can be problematic as they may interact with other grounded surfaces or other electric fields. This can cause unintended changes in the current flows between the 2 plates. This limitation is overcome by placing a “guard” field around the sensor. The guard field is driven in phase with the sensor and surrounds the sensor

Fig. 2 A Typical Sensor Configuration

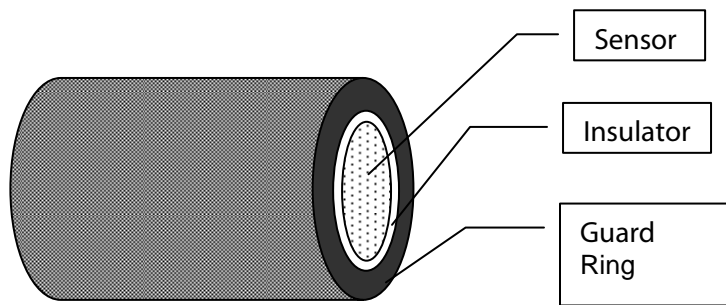
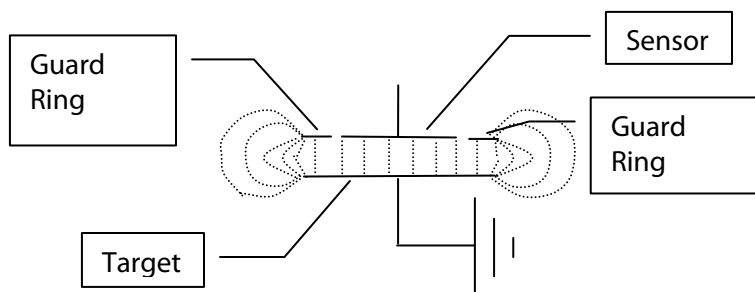

Fig 3 Sensor Side View – Guard Ring Protects Sensor



As can be seen from figure 3 the electric field is now protected by the guard fields. Most capacitive sensors use this type of scheme.

1.4 Types of Capacitive Sensors

Capacitive sensors come in 2 basic varieties, passive and active. The distinction is based on whether there are any electronic components in the sensor or not.

Passive sensors do not have any electronics in their sensors. The sensor signal line is shielded by the guard line from the sensor face back to the electronics package. The ADE Technologies MicroSense 4810 and MicroSense 8810 are examples of passive systems. The probe cable forms an integral part of the sensor and the sensor to guard capacitance should be minimized.

Typical passive sensor



Passive systems have some significant advantages. These include greater flexibility in probe configuration, stability, and lower cost. Their disadvantages include cable length restrictions (typically 3 meters, up to 7 meters is possible), lower bandwidth and lower drive frequency, which makes them unsuited for some applications.

Active systems place a certain amount of electronics in the probe head very close to the sensor. This can be as simple as a few diodes or as complex as a small circuit board. Typically, some portion of the electronics package must be fully enclosed within the guard shield.

Typical active sensor



Active systems are not as subject to cable length restrictions, They operate at much higher frequencies and higher output bandwidths. They are particularly well suited to applications which may involve stray electrical noise on the target such as spindle run out analysis. The disadvantages of active systems include higher costs and less configuration flexibility.

1.5 Performance:

One of the principle characteristics of a capacitive sensor is its ability to achieve very high resolutions, often better than 1 nm (10^{-9} M, 10^{-7} In) at bandwidths between 1kHz and 100kHz. The performance of a system can be characterized by the tradeoffs between Sensor Size, Range, Resolution and Bandwidth.

1.5.1 Sensor Size

In general the larger the sensor size the better the resolution. Typical sensors are round and vary in size from about 0.5mm to 10mm in diameter but there is no special constraint on shape or size. Sensor Size needs to be chosen with an eye on the size of the target. Sensor size should be smaller than the target. The following diagram gives some guidelines for choosing a maximum sensor size.

Sensor size should be as large as practical. As a general rule a doubling of the sensor area will halve the RMS noise. Sensor Size also effects the range. The larger the sensor the larger the practical range. As a general rule for round sensor the diameter of the sensor should be no less than 4 times the total range. Larger ranges are possible at the cost of a decrease in linearity and resolution.

1.5.2 Sensor Size depends on target shape

Fig.4 Determining Sensor Size based upon Target Shape

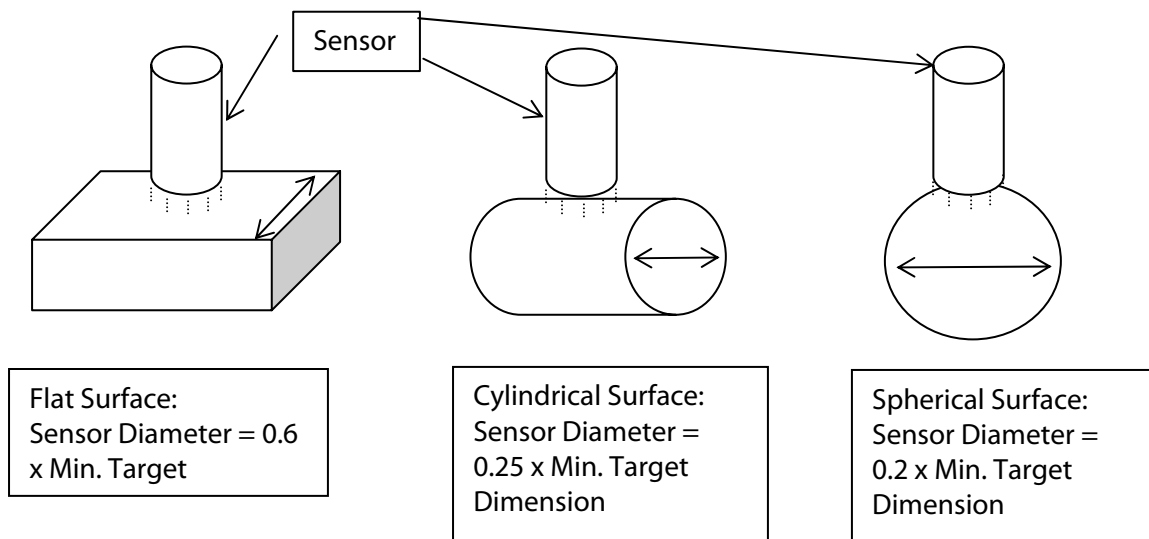

1.5.3 Spatial Resolution

One drawback to larger sensors is reduced spatial resolution. Capacitive sensors take an average reading of the surface under the sensor. Smaller sensors have a better ability to distinguish small features on a part.

Figure 5. Sensor Size determines Spatial Resolution

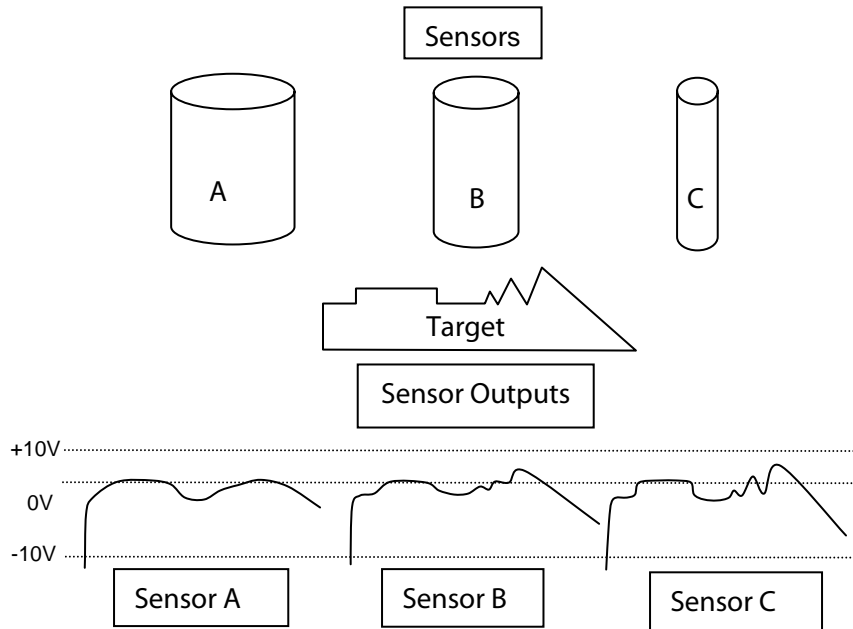

1.5.4 Range & Standoff

Standoff is defined as the distance from the face of the probe to the center of the range. This is an approximate distance. Range is the measuring range of the probe. As a general rule the standoff distance is approximately equal to the total range. Special standoff/range relationships can be configured. Typical ranges for a capacitive measurement systems are from +/- 10 um (+/- 0.0004in) to +/- 1000 um (+/- 0.040 in). Ranges in excess of 25mm (1 in) are possible under special circumstances.

Figure 6. Range and Standoff

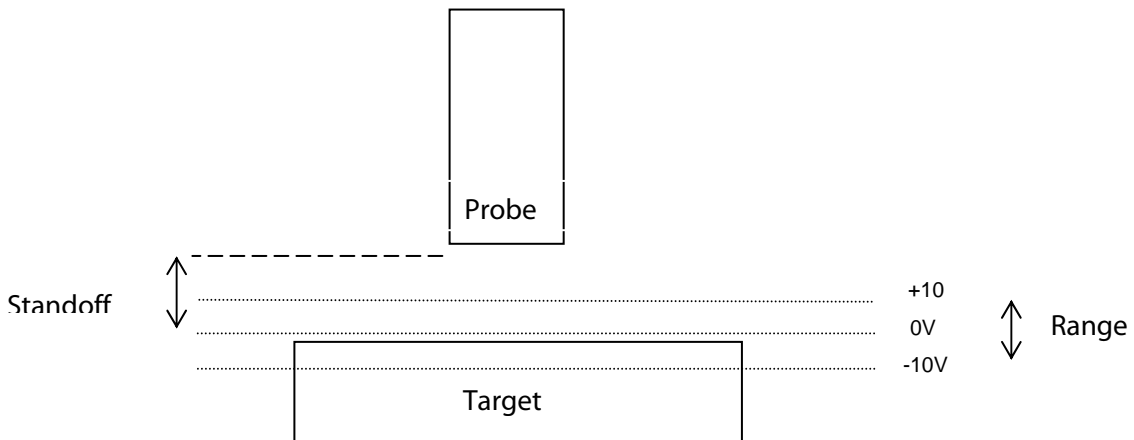

1.5.5 Resolution

Resolution is the smallest increment of displacement that can be measured at a particular bandwidth. ADE Technologies specifies resolution as an RMS value, since it is measured with a true RMS meter which provides an unambiguous result. Smaller operating ranges, larger sensors, and lower bandwidths all improve resolution performance.

1.5.6 Bandwidth

One of the principal advantages of non-contact capacitive measurement is its ability to measure very rapid motion. Applications such as servo control, spindle analysis, and vibration analysis often require the ability to measure very small very fast motions. Active systems such as the MicroSense 5810 and MicroSense 6810 are designed for the most demanding of these applications with filter bandwidths to 100kHz. Passive systems such as the MicroSense 4810 and MicroSense 8810 can also work well at bandwidths up to 20kHz. There is a tradeoff with resolution. The resolution of a system is proportional to the square root of the bandwidth.

ADE Active systems offer both Bessel and Butterworth filters, ADE Technologies Passive systems offer Butterworth filters. Filters are selected in software or by jumpers on the boards.

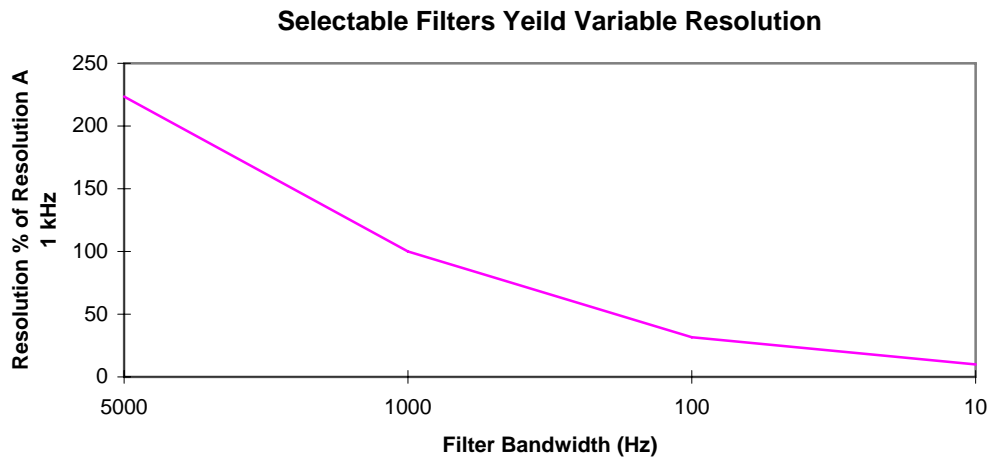

1.5.7 Linearity

The standard output of an ADE capacitive sensor is an analog voltage (+/- 10v). Systems are calibrated so that there is a linear relationship between distance and voltage. Typically there will be a small systematic error in this relationship that is attributed to linearity error. For standard systems this is typically less than 0.1% of the full range. Linearity has become less of an issue in the past 10 years with the advent of inexpensive computers and A/D cards. While a system may have some built in non-linearity this relationship is repeatable to within the resolution parameters and can be compensated for with simple software corrections. ADE Technologies provides linearity compensation data with all its systems.

1.5.8 Stability

Sensor stability is a function of a variety of many factors. These can generally be broken into internal and external factors. For many measurements such as spindle analysis, servo control or other short duration relative measurement stability is not an issue. For measurements where accuracy is required over longer periods of time (from 10's of minutes to years) careful control of external factors and selection of sensing systems is critical.

Temperature is the biggest external factor that must be controlled or compensated. For many systems the customer will have to pay particular attention to the thermal stability of the fixturing system. On systems with long term stability requirements ADE Technologies can provide thermal and humidity coefficients for use in error budget analysis. For many applications, such as thickness measurement, regular checking of a master part or reference surface can minimize stability issues.

Internal stability factors include the choice of sensing system and the materials used in probe construction. As a general rule ADE Passive systems such as the MicroSense 4810 and MicroSense 8810 have better long-term stability characteristics than Active Systems such as the MicroSense 5810 and MicroSense 6810. Typical probes are constructed out of stainless steel and have a thermal coefficient in the area of 200 ppm/degree C. When stability requirements are more stringent and longer term, special sensors are available that are constructed of low coefficient of expansion materials. ADE Technologies can provide systems capable of +/- 50nm stability over 6 months.

1.6 Target Characteristics

The traditional model of a capacitive sensing system has the sensor driven and the target grounded. For optimal performance a conductive path from the target to the sensing electronics is required. The target may be capacitively grounded. Capacitances of 1000 pF or higher work well.

A poorly grounded target will be more susceptible to noise pickup. An example of this problem is found in motor test systems. The spinning shaft of the motor rides on a bearing system and is capacitively coupled to ground. In addition the motor windings and motor control system add electrical noise to the system. Active systems with their higher drive frequencies work better in these applications than passive system.

Target resistance of less than 100 k ohms will not cause measurement errors.

1.7 Environmental Considerations

The primary environmental consideration for a capacitive sensor is that there is a uniform, nonconductive material between the sensor and the target. In most applications this material is air. However, Capacitive Sensors work very well in vacuum environments, including UHV.

Probes should be kept clean. Dirt particles on the sensor face can change the electrical geometry of the sensor and effect measurement. Capacitive Sensors do not work well in on

line cutting and grinding environments where there is a steady stream of cutting fluids and grinding waste.

Capacitive probes, particularly passive probe are very robust and can be subjected to high g loads

1.8 Fixturing

A major advantage of capacitive sensing is its ease of fixturing.

1.8.1 Probe Clamping

The probes should be held in the regions indicated on the drawings. Most probes can be mounted with a split ring or collet or by attaching with mounting holes in the probe. Do not use a setscrew to secure axial probes since it may distort the probe body and affect calibration.

1.8.2 Target Angle

The angle of the probe face to the target is important for obtaining a quality measurement. The smaller the standoff and range for a given probe size, the more critical the angle of the probe face to the target. Angular deviations result in increases in nonlinearity and in signal gain (cosine error). The following charts illustrate typical increases in nonlinearity and gain for the 2800 series probes at the close and far ranges. "Close Range" corresponds to standard small range for probe and "Far Range" corresponds to the largest standard range.

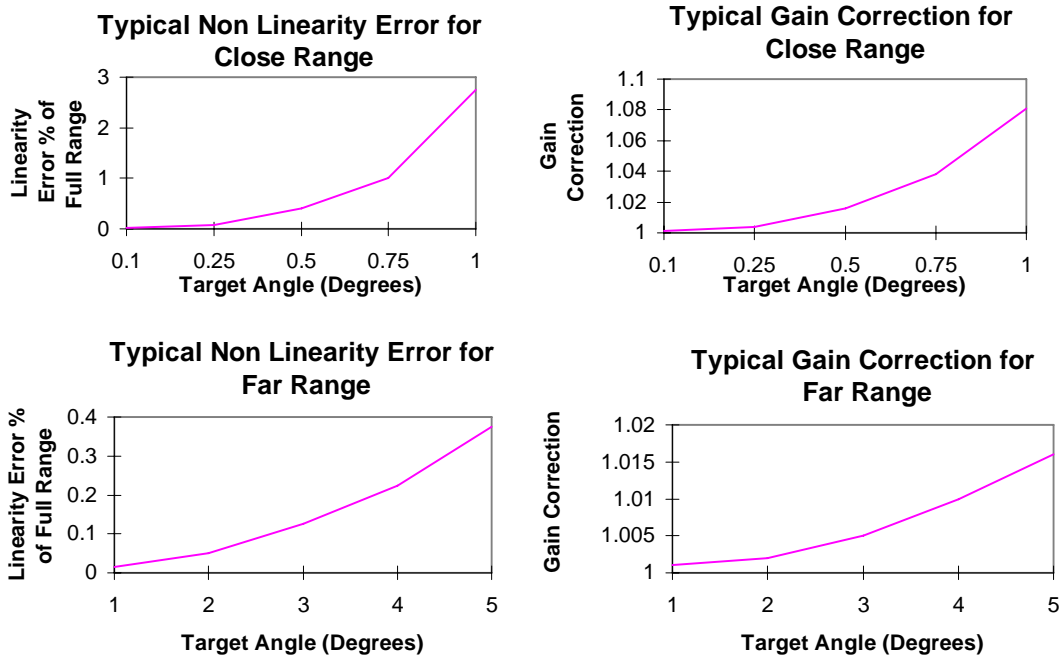

1.8.3 Cable Fixtures

The cable is an integral part of the probe. When routing the cable, avoid bends of constant radii less than 25 mm (1 inch). Avoid rolling bends of radii less than 75 mm (3 inches). Do not secure the cable in a way that will produce distortion or abrasion. For maximum reliability, secure the cable 25 mm to 75 mm (1-3 inches) from the probe. Do not clamp the cable in areas where there is active flexing.

For additional information on high resolution capacitive position sensors, please go to our website located at www.adetech.com